



Southwire™

TOOLS & EQUIPMENT



MATERIAL HANDLING SOLUTIONS

**BUILT FOR DURABILITY.
BUILT FOR RELIABILITY.
BUILT FOR WORK.™**

1-855-798-6657 | SOUTHWIRETOOLS.COM

©2018 Southwire Company, LLC. All rights reserved.
*Registered Trademark & ™Trademark of Southwire Company, LLC.



Southwire™ TOOLS & EQUIPMENT

PIANO BOXES

The Piano Boxes feature shelves, an interior storage grid for hanging items, gas spring guards to protect springs from shifting-load damage, and at-a-glance easy access for small, big and in-between tools, equipment and supplies. This box is ideal for storage and security on the jobsite, workshop or in the plant.

PB603034

- When the cover is closed, PB603034 box can be used as a work table
- Caster-ready 7-gauge steel skids to accommodate optional casters
- Four-way skids allow access from any side, making it easier and faster to transport
- Recessed handles for positive gripping even with gloves on
- Recessed lock housing for protection against theft
- Improved ball stud bracket - added strength reduces the potential for breakage and improves durability
- 60" Width x 30" Depth x 34" Height
- Casters shown are sold separately



598222



We've got it
MADE IN AMERICA™

**BUILT FOR DURABILITY.
BUILT FOR RELIABILITY.
BUILT FOR WORK.™**



PB483048

- Bi-fold cover folds completely out of the way for unrestricted access
- Caster-ready 7-gauge steel skids to accommodate optional casters
- Recessed handles for positive gripping even with gloves on
- Recessed lock housing for protection against theft
- Fits perfectly in the width of a full-size truck bed
- Heavy-duty hinges are extra durable and resist pry-ins
- 48" Width x 30" Depth x 48" Height
- Casters shown are sold separately



We've got it
MADE IN AMERICA™



598223

PB603049

- Caster-ready 7-gauge steel skids to accommodate optional casters
- Recessed handles for positive gripping even with gloves on
- Gas spring guards to prevent damage from shifting loads
- Recessed lock housing for protection against theft
- 60" Width x 30" Depth x 48.5" Height
- Casters shown are sold separately



We've got it
MADE IN AMERICA™



598224

1-855-798-6657 | SOUTHWIRETOOLS.COM

©2018 Southwire Company, LLC. All rights reserved.
*Registered Trademark & ™Trademark of Southwire Company, LLC.



COMPACT CHESTS

CC482423

- Double lock system with one-time lock installation
- Caster-ready 7-gauge steel skids to accommodate optional casters
- Heavy-duty 16-gauge steel construction with fully arc-welded seams
- Four-way skids allow access from any side, making it easier and faster to transport
- Built-in tool tray
- Powder-coat finish for superior durability and corrosion resistance
- Recessed handles for positive gripping even with gloves on
- 48" Width x 24" Depth x 22.5" Height
- Casters shown are sold separately



598226



We've got it
MADE IN AMERICA™

CC191932

- Caster-ready 14-gauge steel skids
- Recessed lock housing for protection against theft with one-time lock installation
- Four-way skids allow access from any side, making it easier and faster to transport
- Powder-coat finish for superior durability and corrosion resistance
- Heavy duty hinges to resist break-in
- Heavy-duty 16-gauge box construction
- 19" Width x 32" Depth x 19" Height



We've got it
MADE IN AMERICA™

630360

**BUILT FOR DURABILITY.
BUILT FOR RELIABILITY.
BUILT FOR WORK.™**



SPECIALTY BOXES

F0604482

- Single recessed lock system for protection and easy access
- Thicker 14-gauge steel bottom provides enhanced structural rigidity, durability and strength, minimizing the possibility of fork lift damage during transport
- Four-way skids allow access from any side for easier and faster transport
- Adjustable and removable split shelves let you organize your storage down below
- Powder-coat finish for superior durability and corrosion resistance
- Dual gas springs for smooth, one-handed lift; one spring locks securely in place
- 60" Width x 44" Depth x 82" Height
- Casters shown are sold separately



598225



We've got it
MADE IN AMERICA™

1-855-798-6657 | SOUTHWIRETOOLS.COM

©2018 Southwire Company, LLC. All rights reserved.
*Registered Trademark & ™Trademark of Southwire Company, LLC.



SouthwireTM TOOLS & EQUIPMENT

SPECIALTY BOXES

CB603065

- Load capacity 1,200 lbs. evenly distributed
- Shelves are 14 in. deep with a 1 in. hemmed lip
- 16-gauge fully arc-welded steel construction
- Powder-coat finish for superior durability and corrosion resistance
- Opens to 12" Width x 14" Depth x 65" Height
- Caster included



598227



We've got it
MADE IN AMERICA™

**BUILT FOR DURABILITY.
BUILT FOR RELIABILITY.
BUILT FOR WORK.™**



SPECIALTY BOXES

CB602460

- Vertical storage area features a bracket for hanging extension cords, clothing or tool belts
- Four-way skids allow access from any side, making it easier and faster to transport
- Powder-coat finish for superior durability and corrosion resistance
- 60" Width x 24" Depth x 60" Height
- Casters shown are sold separately



598228



We've got it
MADE IN AMERICA™

1-855-798-6657 | SOUTHWIRETOOLS.COM

©2018 Southwire Company, LLC. All rights reserved.
*Registered Trademark & ™Trademark of Southwire Company, LLC.



STOR MAC™ SECURITY STORAGE CHESTS

- Tough steel wire mesh
- Four 6" heavy duty casters (standard)
- For high visibility storage
- Reinforced frame & door
- Removable shelves
- Lockable doors
- Load capacity 1,500 lbs
- Competitively priced

HIGH VISIBILITY STORAGE



Removable Shelves



Two point locking doors use Master Lock No. 5.

STOR MAC™ 60



784920

STOR MAC™ 48



785921

STOR MAC™ 30



785920

**BUILT FOR DURABILITY.
BUILT FOR RELIABILITY.
BUILT FOR WORK.™**



WELDBOX™

The Ideal Storage Chest for All Welders & Electricians

- Two-point latching system requires only one lock (WeldBox 3617)
- Weld Box 3617 is caster ready
- 16-gauge steel construction (WeldBox 3617, WeldBox 2812)
- Powder-coat finish for superior durability and corrosion resistance



WB2008
779910



WB2812
779911



WB3617
779928

1-855-798-6657 | SOUTHWIRETOOLS.COM

©2018 Southwire Company, LLC. All rights reserved.
*Registered Trademark & ™Trademark of Southwire Company, LLC.



JOBSITE INVENTORY MANAGEMENT CARTS

- Multiple adjustable shelves
- 6" durable non-marking hard casters for easy mobility
- Top and bottom locking bars for added security
- Powder-coat finish for superior durability and corrosion resistance
- Welded fork tubes for fast and easy transportation
- Quick access to commonly used items with external bin storage brackets
- Wide opening doors for easy access to materials
- Reinforced hinges for added security
- Hoistable from attached lifting points for movement to elevated jobsites



630359

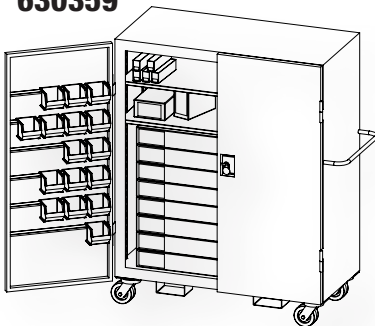

JSIM2D

- 2-Door solid metal construction

630358

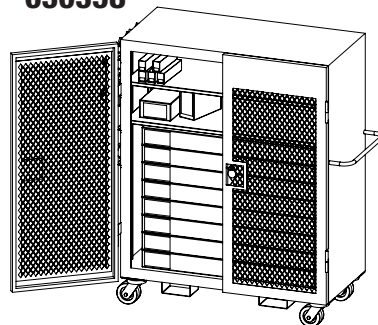

JSIM2DEX

- 2-Door mesh construction

631478

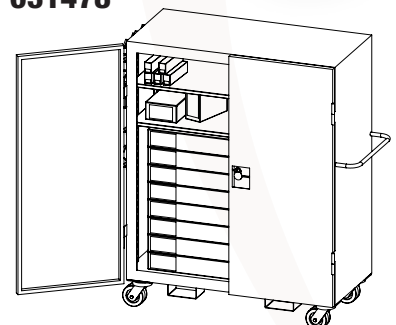

JSIM4D

- 4-Door inventory management cart



CADDY MAC™ 1

Transports spools on spindles and works as a dolly.
Wire is dispensed while laying flat

- 1/2" solid spindles are attached to cart.
- No loose pieces. Spindles lock into place, even during transport.
- Spindles swing out to set position for convenient loading of wire spools.



783398

CADDY MAC™ 2

The ideal storage chest for all welders
and electricians

- Spindles can be easily removed for the occasional use of larger spools.
- Inner spindles store in special loops which can hold four pieces and will not fall out during transportation.
- Hinge design allows easy access to all spools for wire dispensing and folds for compact storage.

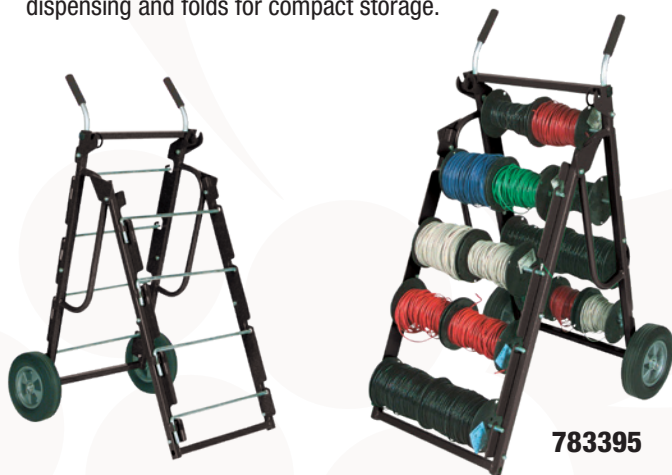

783395

CADDY MAC™ 3

Caddy MAC™ 3 is a versatile wire cart that
doubles as a dolly.

- Uses five 5/8" diameter spindles
- Unique spindle locking system, no loose clips
- Storage loops retain up to 5 spindles
- Dual wire guides
- Large spool capacity



783400

1-855-798-6657 | SOUTHWIRETOOLS.COM

©2018 Southwire Company, LLC. All rights reserved.
*Registered Trademark & ™Trademark of Southwire Company, LLC.



10-PACK MAC™

Feed handle and guide loops are built into one part

- Handle/guide loop position controlled by plunger: 4-positions, no loose parts
- Spindles fold up & lock
- Mast swivels 360°, but can be locked in fixed positions
- Mast may be removed for compact storage
- 4-heavy duty, locking 8" swivel casters
- Travels through a 36" doorway



783366

6-PACK MAC™

Reel spindles fold and lock for convenient storage

- Stores in one-third of the space of conventional dispensers
- Reel spindles fold and lock for convenient storage
- Fits through a 30" doorway
- Two 10" wheels with one 8" locking swivel caster for easy maneuverability
- Welded wire guides for easy payoff
- Stores up to (6) 2,500' spools (18" diameter) of wire



783350



SPOOL MAC™

- All steel frame construction
- 10" wheels for easy transport over rough terrain
- Rollers on spool arm allow for smooth reel rotation and easy payoff
- No loose pieces to account for
- Folding design allows for compact storage
- Fits through 32" doorways
- 350lbs (160 kg) load capacity



783444

HANDI MAC™

All steel frame construction

- Provides extra spool storage for Caddy Mac™ 1 or as a free standing wire dispenser
- Holds up to 8 additional spools
- Spindles are made of sturdy 3/8" steel bar



783490

1-855-798-6657 | SOUTHWIRETOOLS.COM

©2018 Southwire Company, LLC. All rights reserved.
*Registered Trademark & ™Trademark of Southwire Company, LLC.



TAINER MAC™ STACKING CONTAINERS

A MOBILE, HEAVY-DUTY STACKING CONTAINER

- Transports 1,500 lbs. / 680 kg of material
- Large storage capacity
- Four 6" heavy-duty lockable casters
- Posts for stacking & steering
- Stacks with other Sumner Stacking Macs
- Fits through 36" (91 cm) doorway

Stacking saves valuable floor space while still allowing access to the bottom container.



784990

24" x 56" x 32



784989

PERFECT STORAGE FOR:

- Power Cords
- Fittings
- Fasteners
- Safety Gear
- Hardware
- Loose Parts
- Pumps & Hoses
- Pulling Ropes and More!



784988

**BUILT FOR DURABILITY.
BUILT FOR RELIABILITY.
BUILT FOR WORK.™**



KNOCKDOWN MAC™ STACKING CONTAINERS

THE “KNOCKDOWN” VERSION OF SUMNER’S TAINER MAC™

- Transports 1,500 lbs. / 680 kg of material
- Breaks down for easy storage
- Large storage capacity
- Four 6” heavy-duty lockable casters
- Posts for stacking & steering
- Fits through 36” (91 cm) doorway



784987



784986



784985



Southwire™ TOOLS & EQUIPMENT

WIRE WAGON® 550

MOBILE PRINT TABLE AND WORK STATION

- Full-tilt table which allows for ease in plan review
- 8" Eco-rubber tires
- 1,000 lb Capacity for strut or conduit
- Multiple heavy-duty shelves for holding tools and materials



We've got it
MADE IN AMERICA™



568255

**BUILT FOR DURABILITY.
BUILT FOR RELIABILITY.
BUILT FOR WORK.™**



WIRE WAGON® 520

MC CABLE CART

- Comes standard with two sets of axles for wider than normal spools
- 8" Eco-rubber tires
- Can carry up to 2,000lbs of conduit or strut
- Holds 4-spools of 1000' MC cable



We've got it
MADE IN AMERICA™

568250

WIRE WAGON® 510

XL CONDUIT & WIRE CART

- Holds several hundred feet of conduit and more
- Full-use work surface
- 8" Eco-rubber tires
- Holds up to 14-2,1000' spools or a combination of 2,500' and 1000' spools 10, 12 and 14AWG



We've got it
MADE IN AMERICA™

568248

1-855-798-6657 | SOUTHWIRETOOLS.COM

©2018 Southwire Company, LLC. All rights reserved.
*Registered Trademark & ™Trademark of Southwire Company, LLC.



WIRE WAGON® 535

LARGE CAPACITY WIRE CART

- Holds up to 20-500' spools of 12AWG and 14WAG or 6-2,500' spools of 12WAG and 14WAG
- T-handles and heavy-duty casters for easy of movement around the jobsite
- Extra storage shelf for tools, spools and materials
- 8" Eco-rubber tires



568252



We've got it
MADE IN AMERICA™



568251

WIRE WAGON® 530

LARGE SPOOL CART

- Designed for ease of operation
- Holds 8-spools up to 16" in diameter
- Storage for extra tools, spools and materials
- 8" Eco-rubber tires



568254

WIRE WAGON® 538

SERVICE CART

- Holds up to 12-500' spools of 12AWG and 14AWG
- Constructed with 5/8" solid steel bar to support almost any combination of wire spools
- Lightweight and easy to move around the jobsite

BUILT FOR DURABILITY.
BUILT FOR RELIABILITY.
BUILT FOR WORK.™



PIANO BOXES

Model #	Stock #	Description		
PB603034	59822201	PB603034 Piano Box		
Height	Width	Depth	CU-FT	
34"	60"	30"	35.4'	

Model #	Stock #	Description		
PB483048	59822301	PB483048 Piano Box		
Height	Width	Depth	CU-FT	
48"	48"	30"	26.6'	

Model #	Stock #	Description		
PB603049	59822401	PB603049 Piano Box		
Height	Width	Depth	CU-FT	
48.5"	60"	30"	50.5'	

CLAMSHELL CABINET

Model #	Stock #	Description		
CB603065	59822701	CB603065 Bi-Fold Cabinet		
Height	Width	Depth	CU-FT	
65"	120"	14"	68.4'	

STORAGE CABINET

Model #	Stock #	Description		
CB602460	59822801	CB602460 Two Door Cabinet		
Height	Width	Depth	CU-FT	
60"	60"	24"	50'	

COMPACT CHEST

Model #	Stock #	Description		
CC482423	59822601	59822601 Compact Chest		
Height	Width	Depth	CU-FT	
22.5"	48"	24"	15'	



MINI COMPACT CHEST

Model #	Stock #	Description		
CC191932	63036001	CC191932 Mini Compact Chest		
Height	Width	Depth	Weight	
19"	19"	32"	73 lbs.	

FIELD OFFICE

Model #	Stock #	Description		
F0604482	59822501	F0604482 Field Office		
Height	Width	Depth	Weight	
82"	60"	44"	122.4 lbs.	

JOBSITE INVENTORY MANAGEMENT BOXES

Model #	Stock #	Description		
JSIM2D	630359	Job Site Inventory Management Cart Sheet Metal Construction		
Height	Width	Depth	Weight	
"70	60"	30"	754 lbs.	

Model #	Stock #	Description		
JSIM2DEX	630358	Job Site Inventory Management Cart Expanded Steel Construction		
Height	Width	Depth	Weight	
"70	60"	30"	754 lbs.	

Model #	Stock #	Description		
JSIM4D	631478	4 Door Job Site Inventory Management Cart		
Height	Width	Depth	Weight	
"70	60"	30"	754 lbs.	



WELDBOX™ CONTAINERS

Model #	Stock #	Description		
WB2008	779910	WELDBOX 2008		
Height	Width	Depth	Weight	
9.5"	20.125"	8.5"	12.1 lbs.	

Model #	Stock #	Description		
WB2812	779911	WELDBOX 2812		
Height	Width	Depth	Weight	
11"	28.375"	12"	30.8 lbs.	

Model #	Stock #	Description		
WB3617	779928	WELDBOX 3617		
Height	Width	Depth	Weight	
22.5"	36"	17"	97.9 lbs.	

STORMAC™

Model #	Stock #	Description		
SM30	784920	Stor Mac Security Storage Chest 30		
Height	Width	Depth	Weight	
58"	31.5"	33.75"	210 lbs.	

Model #	Stock #	Description		
SM48	785921	Stor Mac Security Storage Chest 48		
Height	Width	Depth	Weight	
58"	51.5"	33.75"	310 lbs.	

Model #	Stock #	Description		
SM60	785920	Stor Mac Security Storage Chest 60		
Height	Width	Depth	Weight	
58"	63.5"	33.75"	345 lbs.	



WIRE WAGON® CARTS

Model #	Stock #	Description		
WW510	568248	Wire Wagon® 510 - XL Conduit & Wire Cart		
Height	Width	Depth	Weight	
46.25"	29.5"	60.5"	191 lbs.	

Model #	Stock #	Description		
WW520	568250	Wire Wagon® 520 - MC cable cart - holds 4 1000' spools		
Height	Width	Depth	Weight	
32"	52"	60"	125 lbs.	

Model #	Stock #	Description		
WW530	568251	Wire Wagon® 530 - Large Spool Wire Cart		
Height	Width	Depth	Weight	
42"	29.5"	50"	155 lbs.	

Model #	Stock #	Description		
WW550	568255	Wire Wagon® 550 - Mobile print table w/ storage		
Height	Width	Depth	Weight	
42"	32"	54"	180 lbs.	

Model #	Stock #	Description		
WW535	568252	Wire Wagon® 535 - Large Capacity Wire Cart		
Height	Width	Depth	Weight	
42"	29.5"	50"	142 lbs.	

Model #	Stock #	Description		
WW538	568254	Wire Wagon® 538 - Service Cart		
Height	Width	Depth	Weight	
36.5"	26.5"	32.5"	25.5 lbs.	

**BUILT FOR DURABILITY.
BUILT FOR RELIABILITY.
BUILT FOR WORK.™**



TAINER MAC

Model #	Stock #	Description		
TM60	784990	Tainer Mac 60		
Height	Width	Depth	Weight	
40"	33"	24"	200 lbs.	

Model #	Stock #	Description		
TM45	784986	Tainer Mac 45		
Height	Width	Depth	Weight	
40"	30"	24"	138 lbs.	

Model #	Stock #	Description		
TM30	784988	Tainer Mac 30		
Height	Width	Depth	Weight	
40"	30"	24"	126 lbs.	

KNOCK DOWN TAINER MAC

Model #	Stock #	Description		
KD60	784987	KD Tainer Mac 60		
Height	Width	Depth	Weight	
37"	33"	20"	192 lbs.	

Model #	Stock #	Description		
KD45	784986	KD Tainer Mac 45		
Height	Width	Depth	Weight	
37"	30"	20"	180 lbs.	

Model #	Stock #	Description		
KD30	784985	KD Tainer Mac 30		
Height	Width	Depth	Weight	
37"	30"	20"	162 lbs.	



Southwire™

TOOLS & EQUIPMENT



GET SOCIAL WITH US:



/SOUTHWIRETOOLS
/SOUTHWIRETOOLSLATINO



@SOUTHWIRETOOLS



@SOUTHWIRETOOLS



SOUTHWIRETOOLS

**BUILT FOR DURABILITY.
BUILT FOR RELIABILITY.
BUILT FOR WORK.™**

1-855-798-6657 | SOUTHWIRETOOLS.COM

©2018 Southwire Company, LLC. All rights reserved.
*Registered Trademark & ™Trademark of Southwire Company, LLC.